

# An Application of a Computerized Data Acquisition System in Testing of an Auxiliary Power Unit

Ali Dinc

**Abstract**— In this study, an application of a computerized data acquisition system in testing of an auxiliary power unit is made. In this regard, required data acquisition software and hardware, personal computer, instrumentation components including sensors, thermocouples and related elements are selected, procured and installed to the test center. The computerized data acquisition system is implemented for the testing of an auxiliary power unit (APU) which is a gas turbine engine. By using a commercial data acquisition software procured in this project, a software application is written to measure, process and display the test data of APU. Voltage readings are made through data acquisition hardware and those are converted to engineering units and corrected to standard day values (pressures, temperatures, velocities, etc.) by software application to calculate APU performance parameters. Compared to manual testing, manual recording and manual calculations in old system, new computerized data acquisition system provided significant reduction in test times (more than 50%) and similar reductions in fuel and labour costs are obtained. Improved test reliability, repeatability and more consistency between engines are also achieved. Engine life, operational safety and analysis capability are enhanced.

**Index Terms**— engine testing, gas turbine, auxiliary power unit, data acquisition, instrumentation.

---

◆

## 1 INTRODUCTION

Engine testing is done mainly to validate the engine designs. The designers have had to make predictions as to the expected performance since the introduction of gas turbines and engine testing is the only way to demonstrate to both the manufacturer and to the client that his product can meet specified performance objectives [1]. The primary objective of engine testing is to obtain information about the engine or its components, accessories or systems at defined operating conditions [2]. A lot of engine testing studies exist in literature [3], [4], [5]. One of the most important elements of modern engine testing is the data acquisition systems.

## 2 MATERIAL AND METHODS

The aim of the project is to set up a computerized data acquisition system in testing of an auxiliary power unit, including data acquisition hardware, software, computer and instrumentation or sensors. Moreover, the main purpose is to demonstrate that the task of automatic data collection from this test cell facility could be achieved with in-house efforts. One of the building blocks of such a system is definitely the computerized data acquisition system and the related software which makes measurements, calculations and recording. A personal computer based data acquisition hardware and a

commercial software are used [6], [7].

The tests of APU, used to be performed manually (including data recording and process) which are time consuming and therefore not economical in terms of fuel consumption and also lacking the required precision from such a critical component testing. This paper includes a basic description of APU, implementation of the test hardware to the test cell and software application within the scope of testing. The advantages of using an automated data acquisition and processing system in the APU test cell are explained in the conclusion part.

### 2.1 Description of APU

The auxiliary power unit or APU is a small gas turbine engine which provides the auxiliary power for the aircraft. APU's are generally used during ground operation of aircraft when the main engines not running, however some aircrafts are also able to use an APU during flight for the operation of some auxiliary aircraft systems. Pictures of the engine are given in Fig. 1-2.

GTC85 is an APU which burns jet fuel and produces pneumatic power in the form of large quantities of heated and pressurized air to furnish the energy necessary to operate engine starters, aircraft air conditioning systems, and other air driven equipment [9].

---

• Ali Dinc, Design Engineering Department, Tusas Engine Industries Inc. Eskisehir, Turkey, E-mail: alidinc@yahoo.com



Fig. 1. GTC85 Auxiliary Power Unit [8].

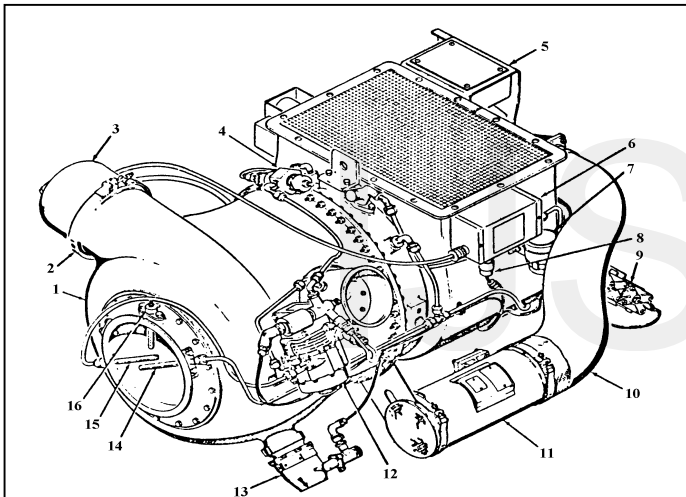

- |                             |                                                           |
|-----------------------------|-----------------------------------------------------------|
| 1. Turbine Section          | 9. Pump and Control Unit - Fuel                           |
| 2. Clamp - Combustor cap    | 10. Duct - Cooling air                                    |
| 3. Cap - Combustor          | 11. Cooler - Oil                                          |
| 4. Regulator - Air pressure | 12. Valve - Unloading and air shutoff                     |
| 5. Bracket                  | 13. Valve - Air Scheduling                                |
| 6. Ignition Unit            | 14. Thermostat - Acceleration and overtemperature control |
| 7. Switch - Oil Pressure    | 15. Thermostat - Bleed load control                       |
| 8. Relay - Time delay       | 16. Thermocouple                                          |

Fig. 2. GTC85 Auxiliary Power Unit [9].

Fig. 3 shows the cutaway of APU. Air is drawn to the first stage compressor through two inlets, one on each side. Air is compressed and collected by a diffuser and passed through a crossover duct down to the inlet side of the second stage compressor. After the second stage compressor air is discharged through a diffuser section to where its pressure is increased while its velocity is reduced. Compressor discharge air is then collected in the Plenum Chamber, the can-like structure built around the turbine section. There is an opening where air may be bled off as pneumatic energy to be converted to useful work. The remaining air will go through the combustion chamber. Hot gases are discharged into the torus chamber enclosing the turbine. The nozzle section causes air velocity to increase and directs the hot gases at the proper angle toward

the turbine blades. After passing through the turbine, air is discharged through the exhaust duct [9].

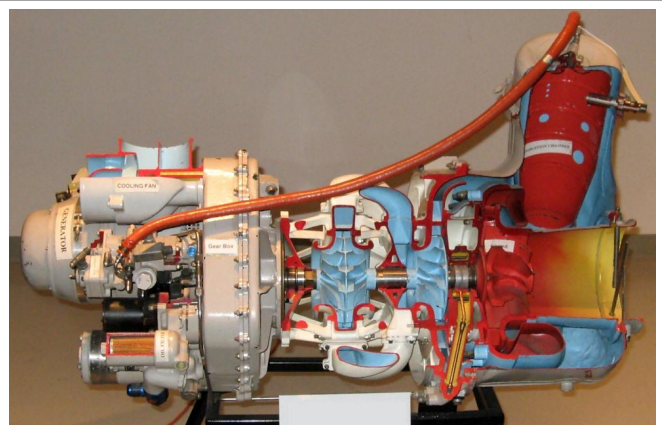

Fig. 3. GTC85 Auxiliary Power Unit [11].

## 2.2 Data Acquisition System Setup

A commercial data acquisition system is installed to the APU test cell. The data acquisition system is composed of a portable mainframe with a multimeter installed internally and a 16-channel multiplexer driven by a personal computer. Maximum sampling rate of the data acquisition system is 13 kHz.

The new data acquisition system is set to measure and record testing data of engine. 15 reading channels of data acquisition system covered most of the parameters of APU. Rotational speed, fuel flow parameters are excluded, since their signals are in pulse or square wave form and this kind of signals re-

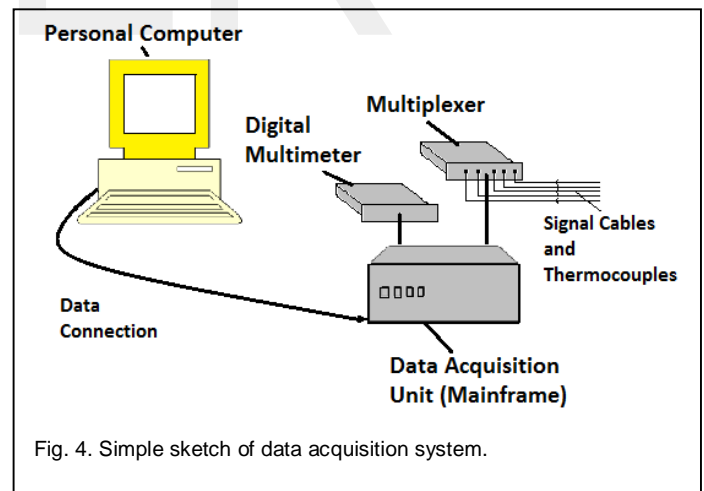

Fig. 4. Simple sketch of data acquisition system.

quire another type of card for reading (counter card) to be procured and installed to data acquisition mainframe. The selected parameters are measured and recorded continuously. These parameters are given in Table 1. For the data acquisition of APU engine, the following hardware is used (Fig. 4):

1. Personal Computer
2. Data Acquisition System comprising of ;
  - Multimeter installed internally
  - Multiplexer
3. Different types of cables, thermocouples and connectors. Thermocouples and pressure transducer signals are con-

ected to new system, being the sources of readings. All channels of the data acquisition system were grounded appropriately and the overall calibration or check is done to maintain the confidence in its accuracy and to avoid the collection of faulty data. Calibration is, in a way, checking and controlling of the route from measuring device or transducer to computer through the data acquisition system by applying prescribed inputs to the measuring system to see the expected value in the range of acceptable limits.

### 2.3 Description of the Software Application

For the test of the APU, the software application written is given in a simplified flow chart in Fig. 5. The aim of the software application is to take measurements, convert the voltage readings into engineering units and perform the necessary calculations with the help of the look-up tables that are used in produced bleed air flow calculation and standard sea level day correction, and to display the results, while writing them in appropriate data files and/or sending them to a printer. Moreover the program runs continuously and interactively.

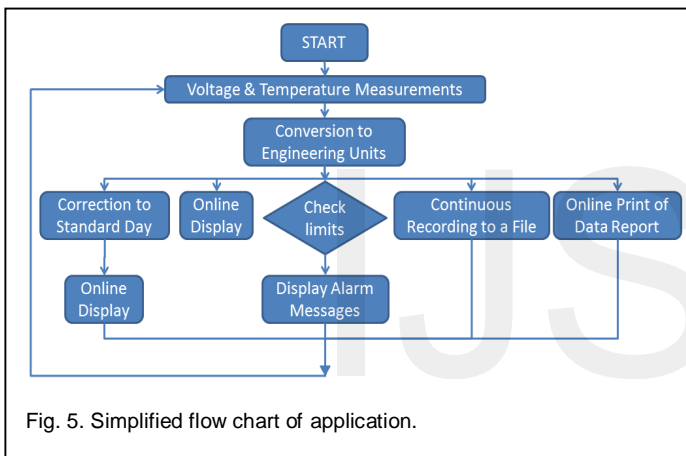

Fig. 5. Simplified flow chart of application.

Panel view of software application which is seen on the computer screen is given in Fig. 6. On the left hand side there are alphanumeric displays of the 15 measured parameters. On the right upper corner, there are 3 main calculated performance parameters ( $W_{corr}$ ,  $P_{corr}$ ,  $T_{corr}$ ) namely corrected mass flow rate, corrected pressure and corrected temperature of bleed air. In the middle, there is a reserved area which alarm messages appear. In addition, there are 5 input cells to enter some unmeasured parameters to be used in calculations or to be included in final summary report. Those are barometric (ambient) pressure, fuel flow rate, engine rotational speed (rpm) and two engine vibrations. When the "PRINT" button is clicked, a summary report of all current values is sent to the printer. The program starts recording every data when "Continuous Recording" button is pressed. Similar displays or charts with different sizes can be added to the next test pages according to the need.

After implementing the system to the APU test cell, overall calibration is performed according to normal procedure and it is found that the new system is more accurate than the existing system. Calibration of pressure parameters are done by applying a number of predetermined pressure values from an air container under pressure to the pressure transducer in its

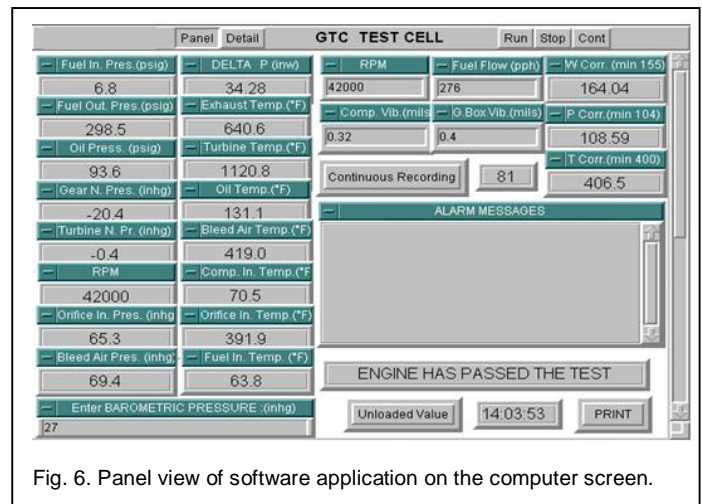

Fig. 6. Panel view of software application on the computer screen.

range, whereas the calibration of thermocouples are done by giving electrical voltages to the end of thermocouple to simulate a temperature value. The calibration operator selects the thermocouple type, a temperature value and the special calibration equipment gives an electrical voltage as an output to the connected thermocouple accordingly. And all these values should be seen with at most 1% error in digital displays and on the computer screen. The test program is written to measure 8 pressure and 7 temperature parameters. Multiplexer channels from 00 to 07 are chosen to measure pressures and channels 08-14 are used for temperature measurements. Expected voltage range is between 1 and 5 volts DC for pressure parameters except  $\Delta P$  which has a voltage range of 40-200 mV DC. Temperatures are directly read as  $^{\circ}C$  by the multimeter. However for pressure measurements, conversion from voltage to pressure must be made by using conversion equations.

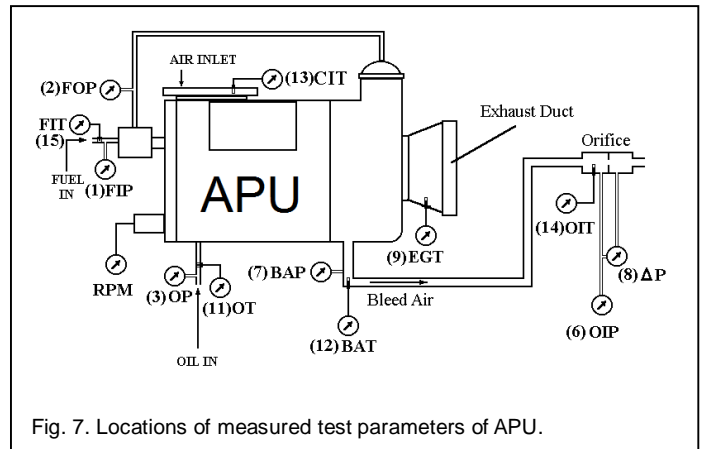

Fig. 7. Locations of measured test parameters of APU.

During the testing of the APU, the parameters as indicated in Table 1 are measured. The locations where these parameters are measured are shown schematically in Fig. 7. The minimum and maximum values of the corresponding parameters [10] are also indicated in Table 1. With the new data acquisition system, these 15 parameters are measured within capability of data acquisition hardware and considered to be significant and influencing the overall performance of the APU. Only 7 parameters of these 15 parameters are used in the calculation of the engine performance and the rest are used for engine monitoring and safety purposes.

TABLE 1  
APU MEASURED PARAMETERS AND TEST LIMITS [10]

Parameter Name	Abb.	Description	Min. Limit	Max. Limit
1. Fuel Inlet Pressure (psig)	FIP	Fuel pressure measured at fuel pump inlet	13	17
2. Fuel Outlet Pressure (psig)	FOP	Fuel pressure measured at fuel pump outlet		
3. Oil Pressure (psig)	OP	Oil pressure measured at oil pump discharge port	80	100
4. Gear Negative Pressure (in.Hg)	GNP	Gear Negative Pressure	-18	-3
5. Turbine Negative Pressure (in.Hg)	TNP	Turbine Negative Pressure	-18	2
6. Orifice Inlet Pressure (in.Hg)	OIP	Orifice Inlet Pressure		
7. Bleed Air Pressure (in.Hg)	BAP	Bleed Air Pressure		
8. Orifice difference pressure (in.H <sub>2</sub> O)	ΔP	Orifice difference pressure		
9. Exhaust Gas Temperature (°F)	EGT	Exhaust Gas Temperature		1200+10
10. Turbine Temperature (°F)	TT	Turbine Temperature		
11. Oil Temperature (°F)	OT	Oil Temperature		135+CIT
12. Bleed Air Temperature (°F)	BAT	Bleed Air Temperature		
13. Compressor Inlet Temperature (°F)	CIT	Compressor Air Inlet Temperature	-65	130
14. Orifice Inlet Temperature (°F)	OIT	Orifice Inlet Temperature		
15. Fuel Inlet Temperature (°F)	FIT	Fuel temperature measured at fuel pump inlet	-65	130

The software application for data acquisition and processing of APU is written using a commercial data acquisition and control software which is an iconic programming language optimized for instrument control. In order to create an application icons are connected to each other accordingly with a mouse. The program resembles a data flow diagram. There are icons for instruments, data analysis, file input/output, data displays in the form of alphanumeric, dial gage meters, fill bars, X-Y graphs and strip charts. Software supports the hardware used in the measurements which means that it has drivers of instruments and commands for configuring and measuring available in the program making easy to learn and to use. Another advantage of software is the capability of building good and useful user interface on the screen using different types of display icons which is very difficult to obtain with a textual programming language like C or Visual Basic. After connecting the icons it has been actually created an executable program [12].

**2.4 Measured and Calculated Parameters**

APU engines were tested according to the technical test procedure. 15 engine parameters Fuel Inlet Pressure (psig), Fuel Outlet Pressure (psig), Oil Pressure (psig), Gear Negative Pressure (in.Hg), Turbine Negative Pressure (in.Hg), Orifice Inlet Pressure (in.Hg), Bleed Air Pressure (in.Hg), Orifice difference pressure (in.H<sub>2</sub>O), Exhaust Gas Temperature (°F), Turbine Temperature (°F), Oil Temperature (°F), Bleed Air Temperature (°F), Compressor Inlet Temperature (°F), Orifice Inlet Temperature (°F) and Fuel Inlet Temperature (°F) (in Table 1) were recorded vs. time and given in Fig. 8-22.

From measured parameters, 3 APU performance parameters are calculated. Those are corrected mass flow rate, corrected pressure and corrected temperature of bleed air ( $W_{corr}$ ,  $P_{corr}$ ,  $T_{corr}$ ) and given in Fig. 23-25 with their acceptance limit

lines.

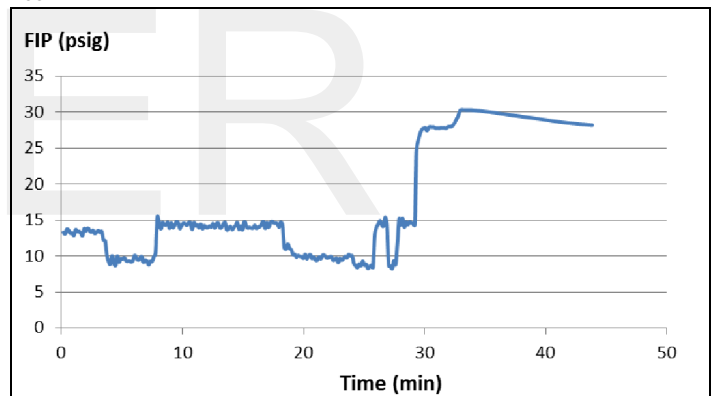

Fig. 8. Fuel Inlet Pressure.

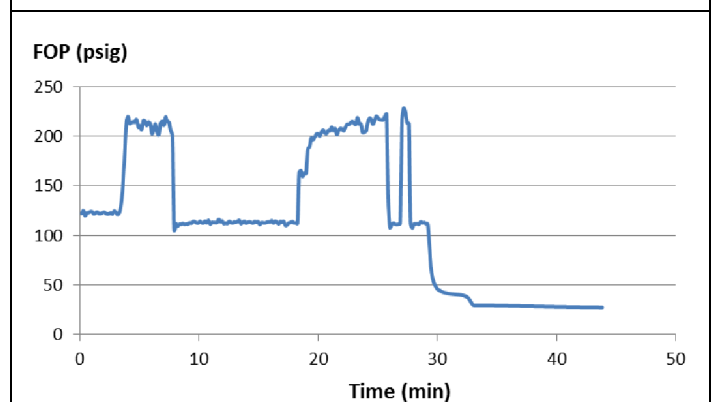

Fig. 9. Fuel Outlet Pressure.

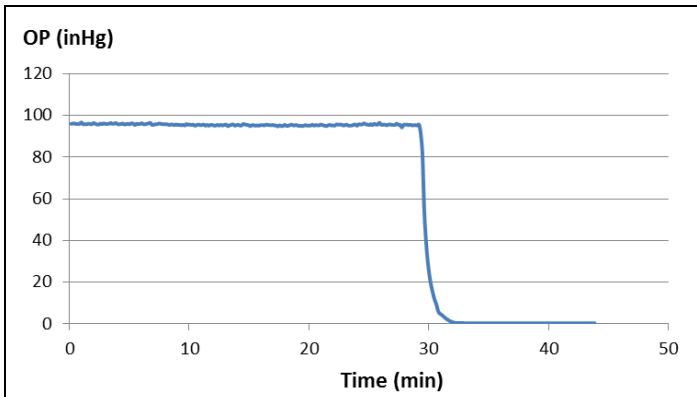

Fig. 10. Oil Pressure.

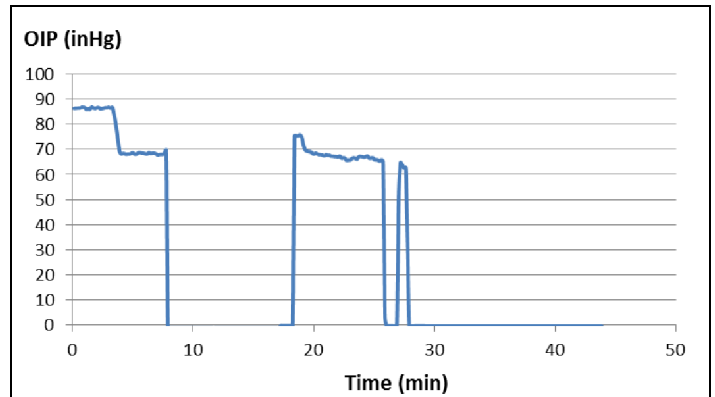

Fig. 13. Orifice Inlet Pressure.

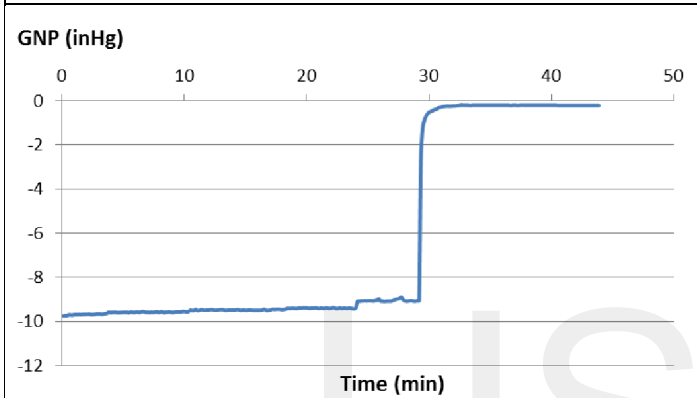

Fig. 11. Gear Negative Pressure.

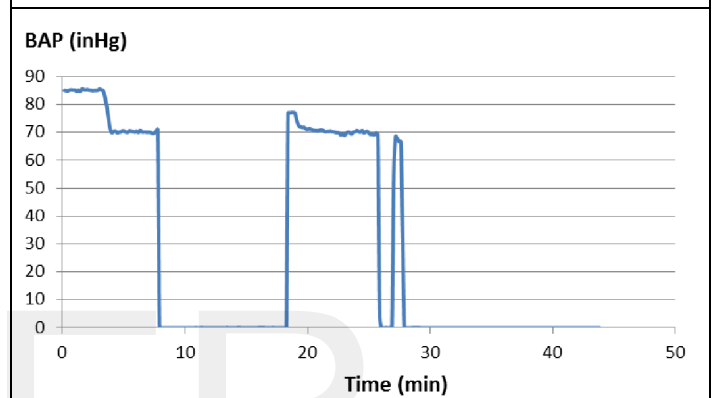

Fig. 14. Bleed Air Pressure.

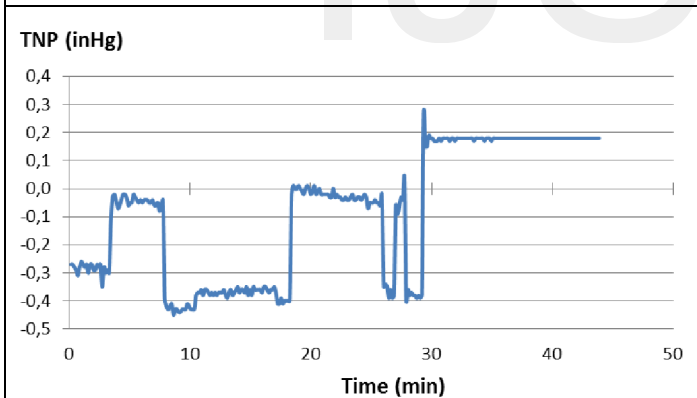

Fig. 12. Turbine Negative Pressure.

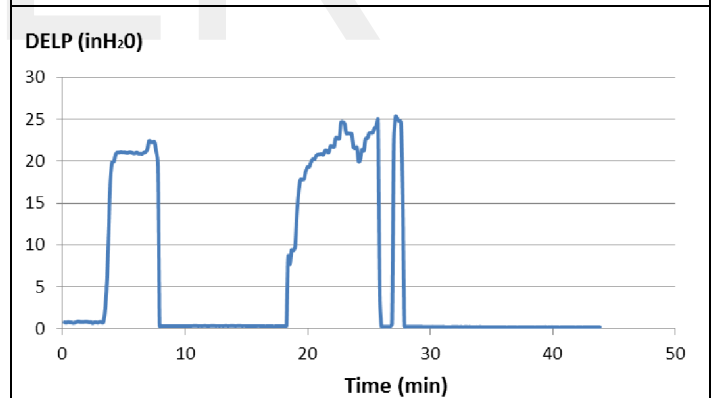

Fig. 15. Orifice difference pressure ( $\Delta P$ ).

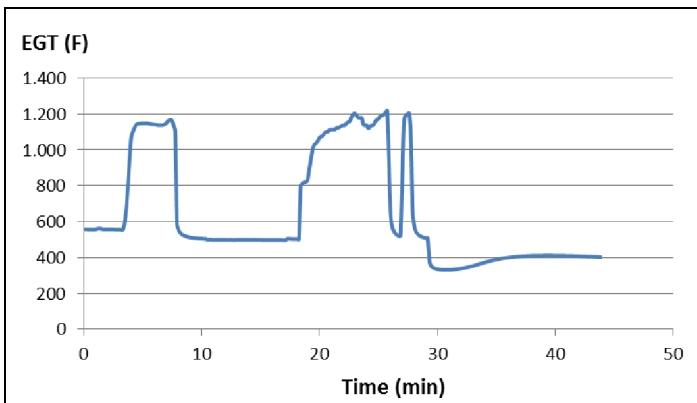

Fig. 16. Exhaust Gas Temperature.

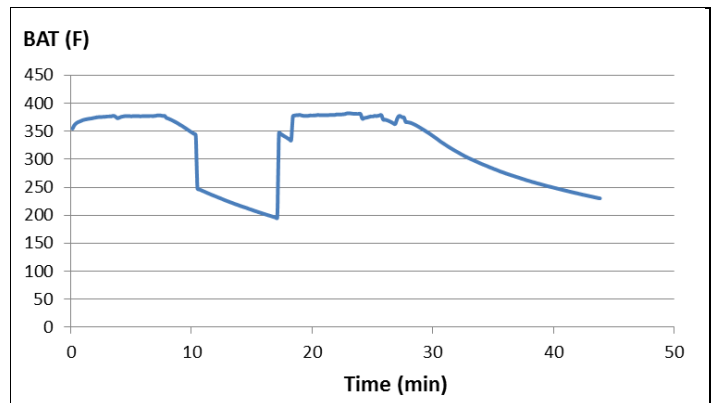

Fig. 19. Bleed Air Temperature.

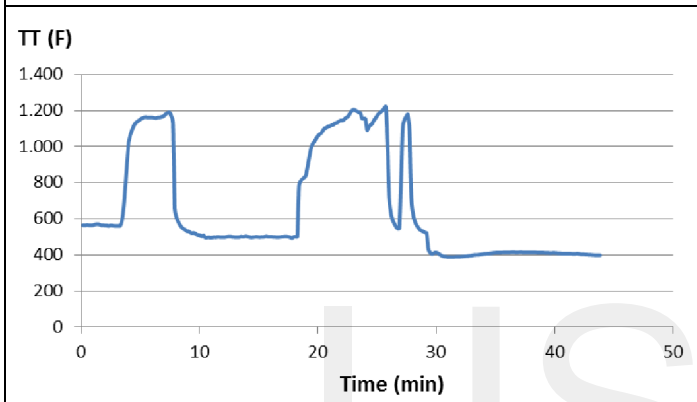

Fig. 17. Turbine Temperature.

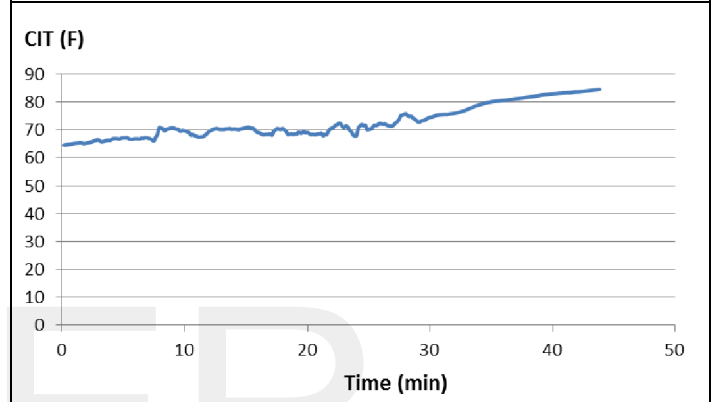

Fig. 20. Compressor Inlet Temperature.

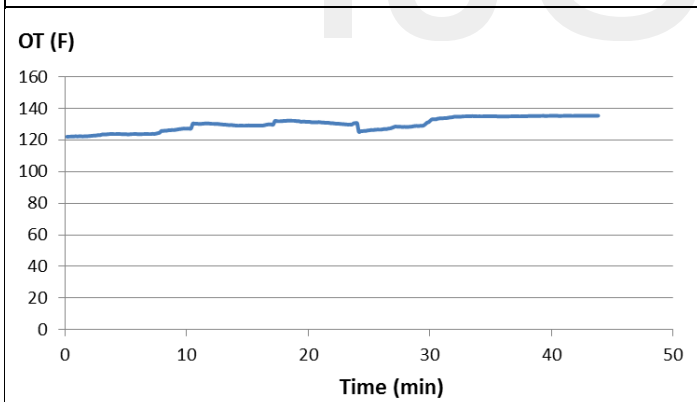

Fig. 18. Oil Temperature.

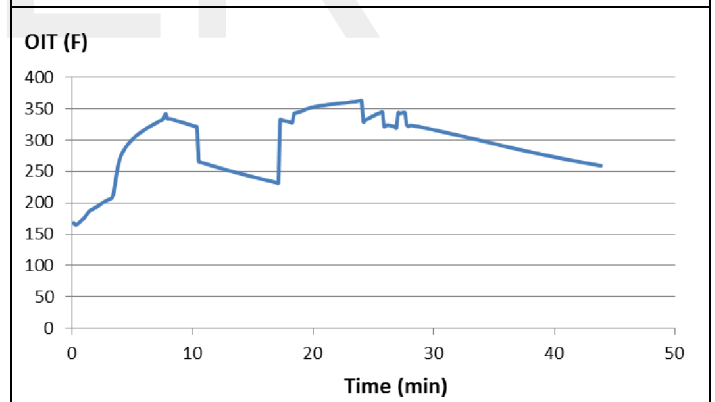

Fig. 21. Orifice Inlet Temperature.

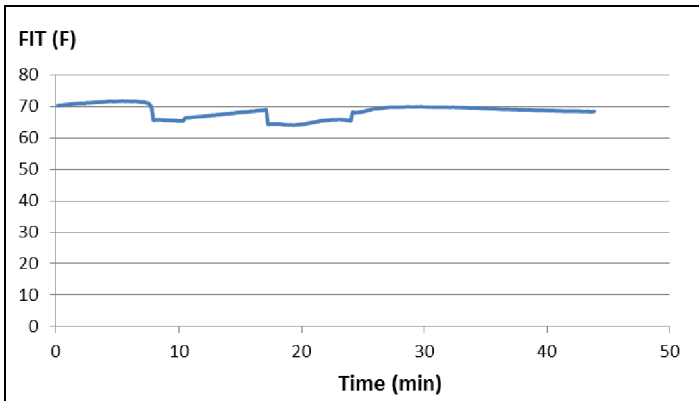

Fig. 22. Fuel Inlet Temperature

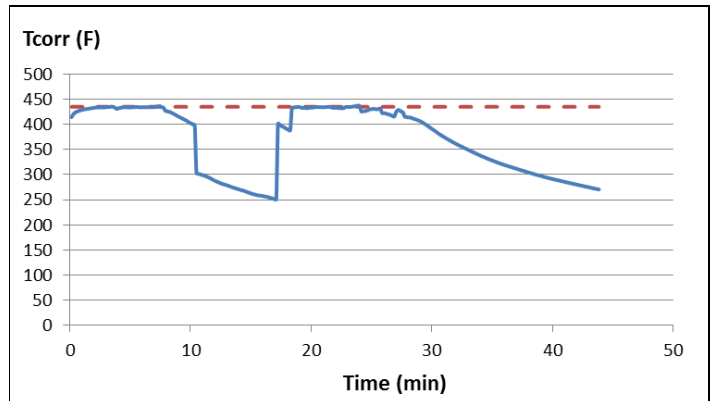

Fig. 25. Corrected temperature of bleed air.

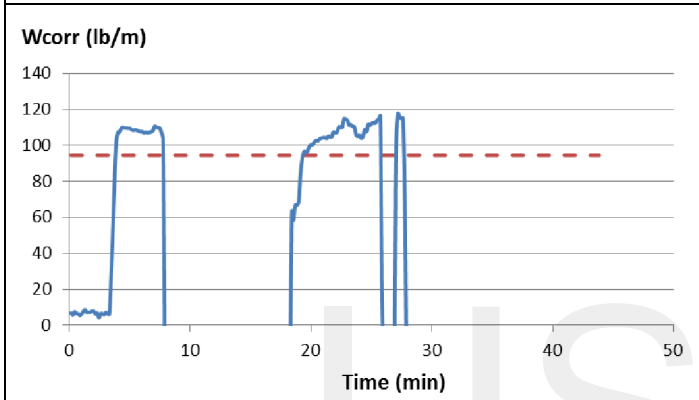

Fig. 23. Corrected mass flow rate of bleed air.

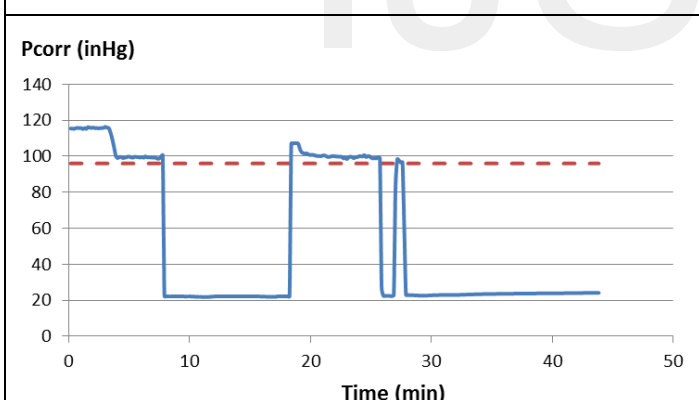

Fig. 24. Corrected pressure of bleed air.

### 3 DISCUSSION

The use of an automated data acquisition and processing system reduces the test times by more than 50%. If we assume that during a normal manual test operation approximately 100 lb. of fuel is consumed per test, this will yield a fuel savings of more than 10000 lb. per year. It has been found that the new data acquisition system has shown the following advantages:

1. Significant reduction in test times; more than 50 %, and similar reductions in fuel and man-hour costs. The use of automated data acquisition system reduces the engine test time compared to manual recording and calculations performed with a hand calculator. Time saving occurs because the system automatically samples, calculates and stores the data for instantaneous display. Previously, the testing was performed manually and there were no on-line calculations. Therefore it was not possible to know whether the engine has passed the test or not which was determined only after performing the calculations. Therefore usually two or more test runs were needed. However, with the new data acquisition system one test run is sufficient to determine whether the engine satisfies the required criteria.
2. Improved test reliability, repeatability and more consistency between engines. The system achieves this reliability and repeatability in a number of ways:
  - a. The data are automatically read and filtered, therefore eliminating operator errors in reading the instruments.
  - b. The performance calculations are carried out by the computer on the acquired data. The test program eliminates not only the errors in reading the instruments, but also those on the calculations such as application of manual correction factors, the interpretation of graphical information.
  - c. The operator does not have to remember all correct engine limits and calculations for different types of engines. Instead this is done by the corresponding computer test programs written for each type of engine.

3. Engine life saving occurs because the new data acquisition system determines precisely the point where the engine meets the required minimum performance limits and this point corresponds to a maximum EGT (Exhaust Gas Temperature). Higher EGT diminishes the engine life and when the new system finds a lower EGT point where still the minimum performance limits are satisfied, engine life will be longer.
4. Operational Safety is much enhanced. The automatic checking of data acquired provides the operator with the "cautionary" and "alert" indications of unsafe operating conditions. This system monitors all the significant parameters more accurately at the specified limit than it can be achieved by an operator with conventional instruments, thus reducing the probability of reaching operating levels which would overstress the engine.
5. Analysis capability is enhanced. The data that are stored during the test provides enormous potential for further analysis.

- [7] A. Dinc, "Design and Implementation of a Data Acquisition System for Testing of Gas Turbine Engines", Journal of Multidisciplinary Engineering Science and Technology, Vol.2 Iss. 3, Mar. 2015.
- [8] [http://commons.wikimedia.org/wiki/File:GTC85-90\\_b.JPG](http://commons.wikimedia.org/wiki/File:GTC85-90_b.JPG), 2015.
- [9] Airesearch Manufacturing Company Of Arizona, "Training Manual GTC85 Series Gas Turbine Compressor Engine", TSG-28
- [10] Garrett, "Technical Manual Model GTCP85", TO 2G-GTCP85-41-1, (1992)
- [11] <https://www.flickr.com/photos/37467370@N08/7460234272>, 2015.
- [12] Hewlett Packard, HP VEE User Manual, 1993.

## 4 CONCLUSION

An application of a computerized data acquisition system in testing of an auxiliary power unit is made. Compared to manual testing, manual recording and manual calculations in old system, new computerized data acquisition system provided significant reduction in test times (more than 50%) and similar reductions in fuel and labour costs are obtained. Improved test reliability, repeatability and more consistency between engines are also achieved. Engine life, operational safety and analysis capability are enhanced.

## ACKNOWLEDGMENT

This project is funded by Tusas Engine Industries Inc. (TEI) and is collaboration with the Aeronautical Engineering Department of the Middle East Technical University in Ankara, Turkey.

## REFERENCES

- [1] D.M. Rudnitski, "Performance Derivation of Turbojets and Turbofans From Tests in Sea Level Test Cells", AGARD-LS-132, 1984.
- [2] M. Holmes, P.G. Booker and B.M. Watts, "Data acquisition and processing in sea level test beds", AGARD-LS-132, 1984.
- [3] A.A. Okafor, C.H. Achebe, J.L. Chukwunke, P.C. Okolie, "Experimental Simulation and Optimization of Performance of Four Stroke Spark Ignition Injector Engine" International Journal of Scientific & Engineering Research, vol. 5, iss. 11, Nov. 2014.
- [4] A. Hossain, S.K. Das, S. Hossain, "Fabrication & Performance Test of a Low Temperature Differential Stirling Engine" International Journal of Scientific & Engineering Research, vol. 5, iss. 1, Jan. 2014.
- [5] A. Srinivasan, K. Tharanisingh, K. Alagarsamy, S. Sundaravaradan, "Testing and Analysis of the Correlation between Engine performance and Engine life", International Journal of Scientific & Engineering Research, vol. 5, iss. 10, Oct. 2014.
- [6] A. Dinc, "Design and implementation of a data acquisition system for testing of gas turbine engines", MS Thesis, Middle East Technical University, Graduate School of Natural and Applied Sciences, Turkey, 1995.